

Dimensioni unità interna

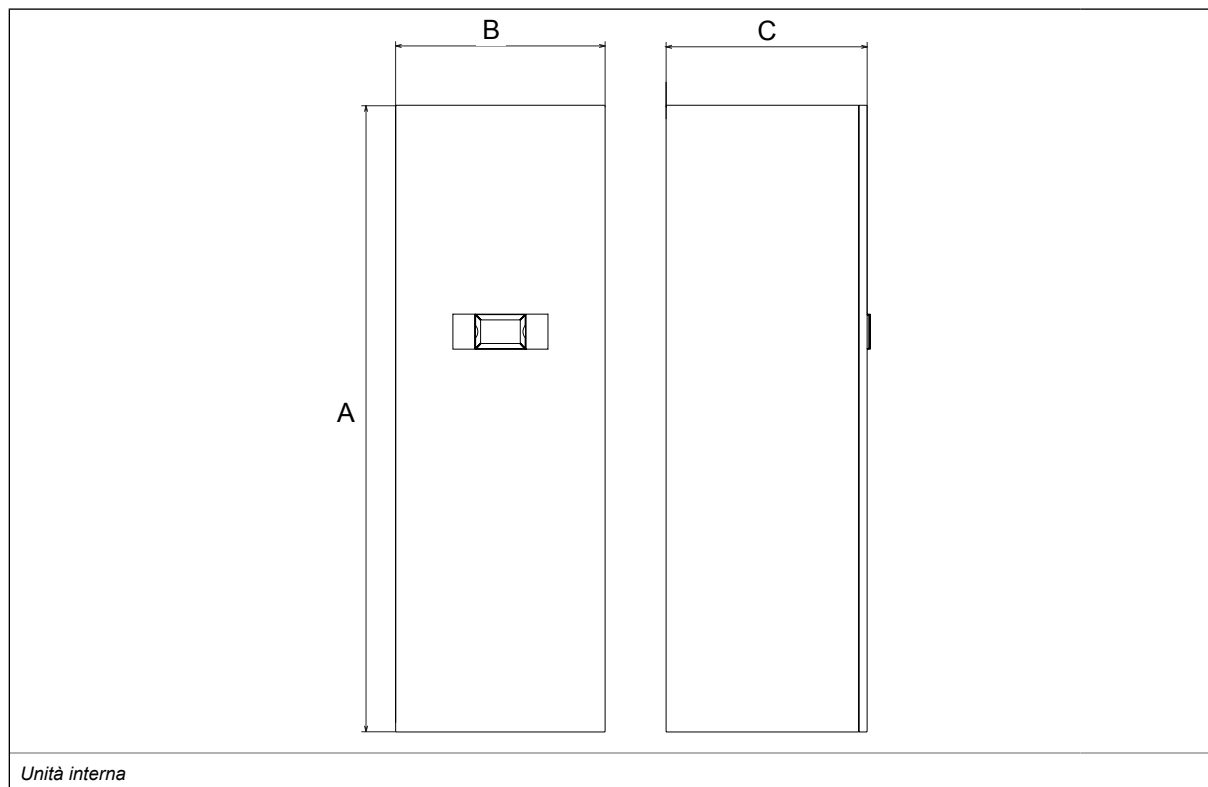

		SHERPA AQUADUE TOWER 7	SHERPA AQUADUE TOWER 11	SHERPA AQUADUE TOWER 13	SHERPA AQUADUE TOWER 13T	SHERPA AQUADUE TOWER 16	SHERPA AQUADUE TOWER 16T
Unità interna		SMALL 599513A		BIG 599512A			
A	mm	1980	1980	1980	1980	1980	1980
B	mm	600	600	600	600	600	600
C	mm	600	600	600	600	600	600
Peso	kg	171	171	173	173	173	173
Peso in uso	kg	183	183	185	185	185	185

Dimensioni e pesi unità interna

Dimensioni unità esterna

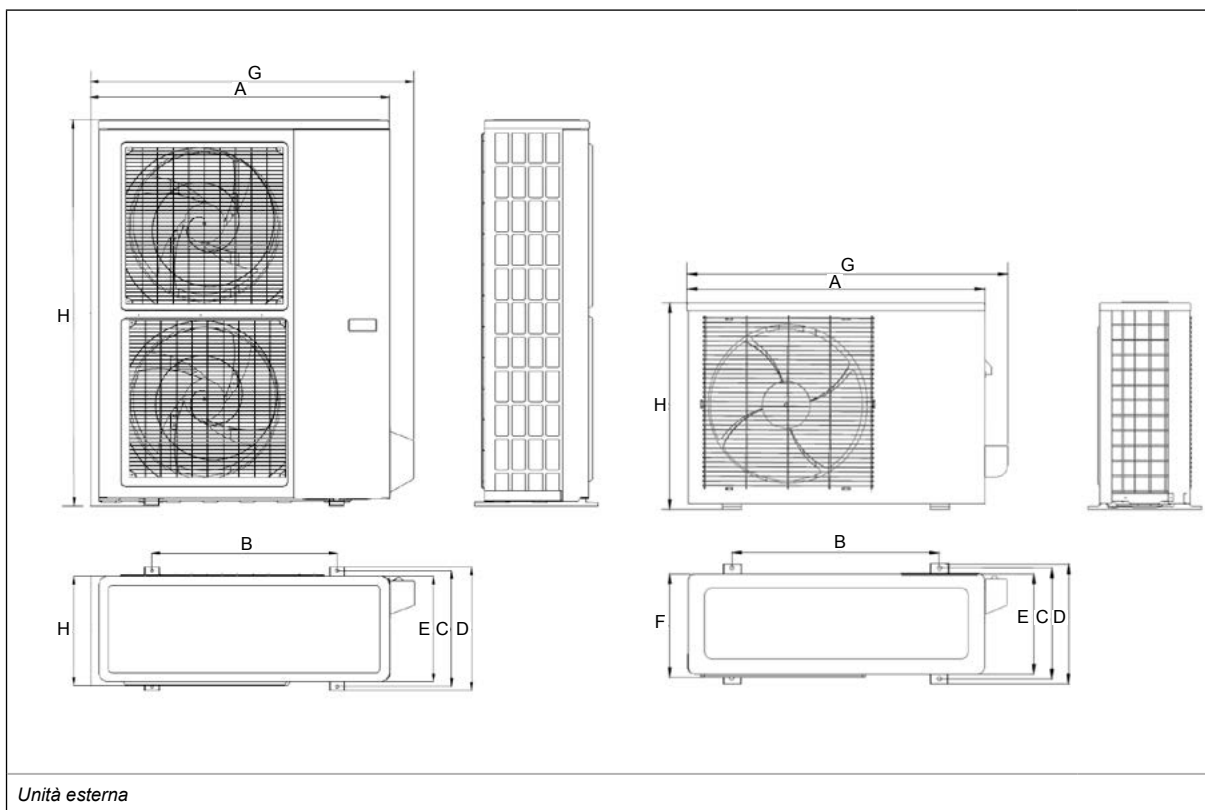

		SHERPA AQUADUE TOWER 7	SHERPA AQUADUE TOWER 11	SHERPA AQUADUE TOWER 13	SHERPA AQUADUE TOWER 13T	SHERPA AQUADUE TOWER 16	SHERPA AQUADUE TOWER 16T
Unità esterna		OS CEBSH24EI	OS CEBCH36EI	OS CEINH48EI	OS CETNH48EI	OS CEINH60EI	OS CETNH60EI
		MONOVENTOLA		BIVENTOLA			
A	mm	847	990	938	938	938	938
B	mm	563	622	633	633	633	633
C	mm	340	368	404	404	404	404
D	mm	360	398	448	448	448	448
E	mm	315	340	370	370	370	370
F	mm	330	350	392	392	392	392
G	mm	917	1060	1008	1008	1008	1008
H	mm	700	950	1369	1369	1369	1369
Peso	kg	58	82	99	102	99	107
<i>Dimensioni e pesi unità esterna</i>							

Dimensioni unità esterna S1

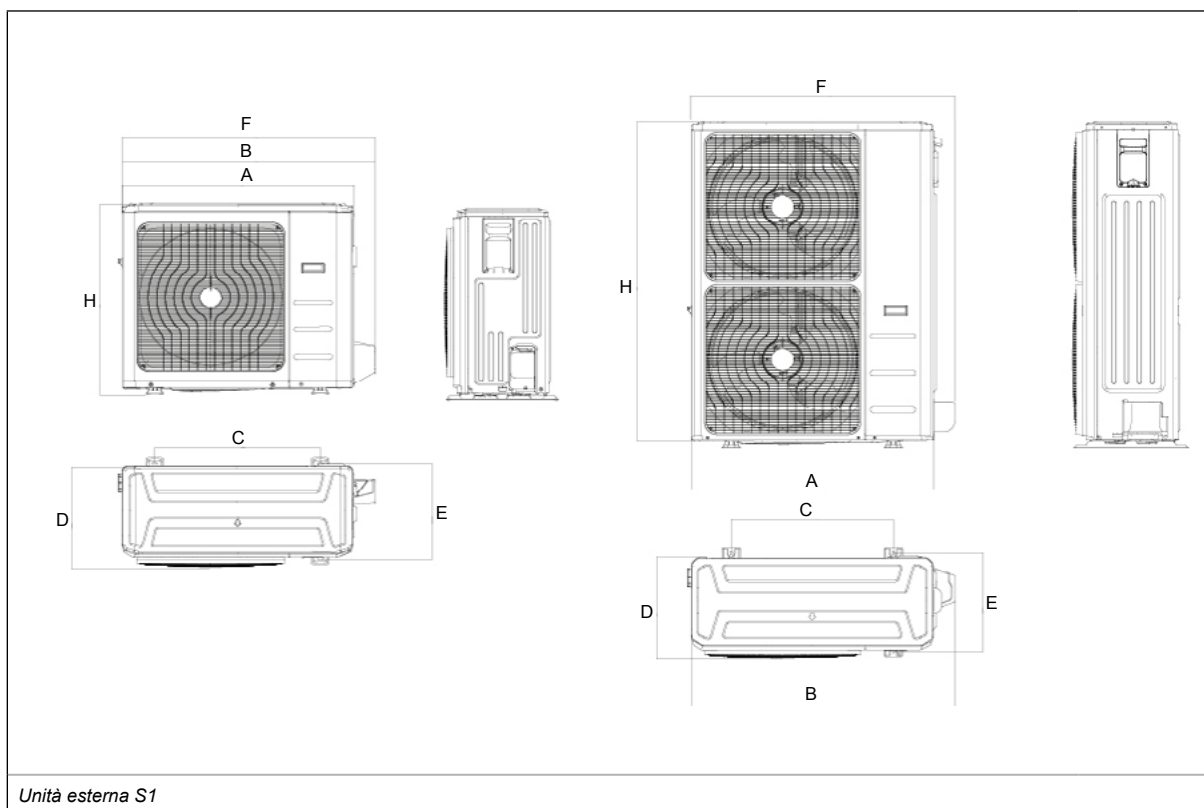

Unità esterna S1

		SHERPA AQUADUE TOWER 7	SHERPA AQUADUE TOWER 11	SHERPA AQUADUE TOWER 13	SHERPA AQUADUE TOWER 13T	SHERPA AQUADUE TOWER 16	SHERPA AQUADUE TOWER 16T
Unità esterna S1		OS CESHH24EI	OS CESHH36EI	OS CESHH48EI	OS CESTH48EI	OS CESHH60EI	OS CESTH60EI
		MONOVENTOLA			BIVENTOLA		
A	mm	845	946	952	952	952	952
B	mm	914	1030	1045	1045	1045	1045
C	mm	540	673	634	634	634	634
D	mm	363	410	415	415	415	415
E	mm	350	403	404	404	404	404
F	mm	915	1036	1032	1032	1032	1032
H	mm	702	810	1333	1333	1333	1333
Peso	kg	49	67	95	108	95	113

Dimensioni e pesi unità esterna S1